

Field application TT100-01 boilers

ENTROPIE boilers TT100-01 are high-temperature three-pass hot water gas-tube boilers with capacity ranging from 1.0 to 16.5 MW.

ENTROPIE boilers TT100-01 are designed for heating buildings and facilities and for providing engineering processes of various purposes.

Under the conditions of transport, storage, installation and operation, the warranty period is 36 months from the date the boiler begins operation, but no more than 42 months from the date of shipment from the manufacturer.

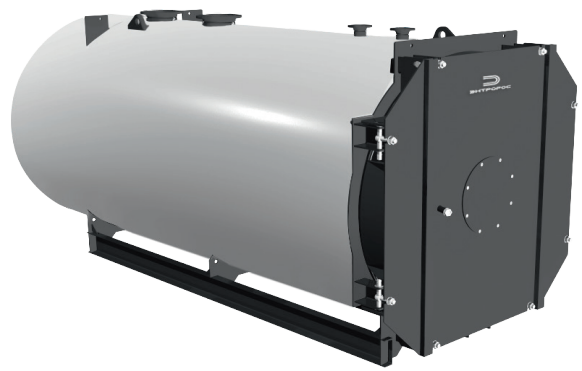

General view of ENTROPIE boiler TT100-01

Diagram of ENTROPIE boiler TT100-01

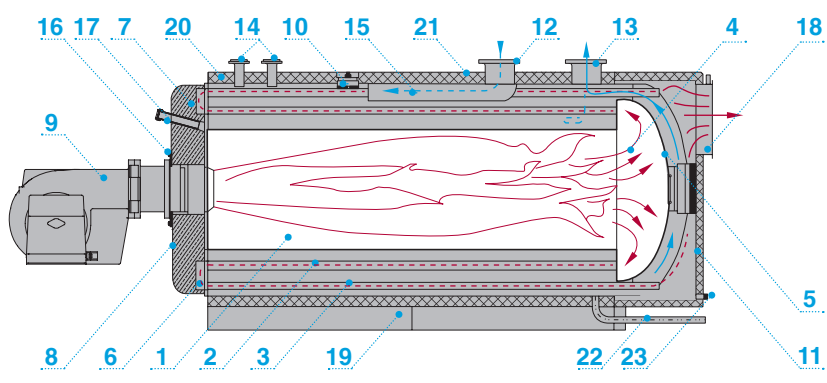

- | | | |
|---------------------------|---------------------|--------------------------------|
| 1 Flue tube | 7 Front door lining | 13 Water outlet |
| 2 Second pass fire tubes | 8 Boiler front door | 14 Emergency valve |
| 3 Third pass fire tubes | 9 Burner | 15 Water guiding element |
| 4 First reversal chamber | 10 Inspection hole | 16 Burner plate |
| 5 Torispherical head | 11 Manhole | 17 Sight glass |
| 6 Second reversal chamber | 12 Water inlet | 18 Flue gas removal outlet |
| | | 19 Steel load-bearing supports |
| | | 20 Heat insulation |
| | | 21 Checkered aluminum coating |
| | | 22 Drainage pipe |
| | | 23 Drain nozzle |

Technical characteristics of boilers TT100-01

Boiler size	1,000	2,000	2,500	3,000	3,500	4,200	5,400	6,500	8,000	10,000	12,000	15,000
Rated heat output, kW												
Maximum water temperature, °C	140											
Minimum water temperature at the boiler inlet, °C	60											
Maximum operating overpressure of water, MPa	0.85											
Minimum water flow rate, m ³ /h	Not regulated											
Minimum capacity of the first stage of burner, %	Not regulated											
Efficiency*, %	91.8	90.9	90.6	90.8	91.8	93.5	93.5	92.0	92.3	92.5	91.1	92.3
Rated water flow rate, m ³ /h	13	25	31	38	44	53	68	81	100	125	150	188
Hydraulic resistance of water path, kPa	0.08	0.16	0.36	0.14	0.13	0.18	0.15	0.26	0.23	0.28	0.26	0.25
Flue gas flow rate, kg/s	0.44	0.90	1.13	1.35	1.56	1.84	2.36	2.88	3.54	4.41	5.37	6.63
Aerodynamic resistance of gas path for maximum capacity, Pa	260	830	1,005	900	1,240	1,240	1,920	1,110	1,250	1,450	1,490	1,810
Temperature of outgoing flue gas, °C	199	217	223	219	199	165	165	196	190	186	211	190
Firebox volume, m ³	0.9	1.3	1.5	2.2	2.4	3.3	4.1	5.2	6.6	8.6	10.8	13.8
Boiler water volume, m ³	1.80	2.80	3.00	4.10	4.60	5.36	6.42	7.40	9.60	12.12	16.00	20.00
Dry boiler weight (weight tolerance 4.5 %), kg	3,013	4,912	5,361	7,374	8,028	10,175	11,595	14,329	17,486	20,442	24,648	30,432

* The efficiency is indicated for natural gas 8,000 Kcal/m³

Overall and connecting dimensions of ENTROPIE boilers TT100-01

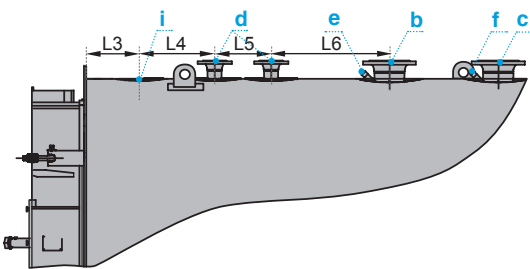

The overall and connecting dimensions of boilers with a heat output of 1,000 kW and 1,500 kW provide for one safety pipe (d); in addition, these boilers have no slinging holes (distance B1). Dimensions L3–L6 in accordance with this drawing.

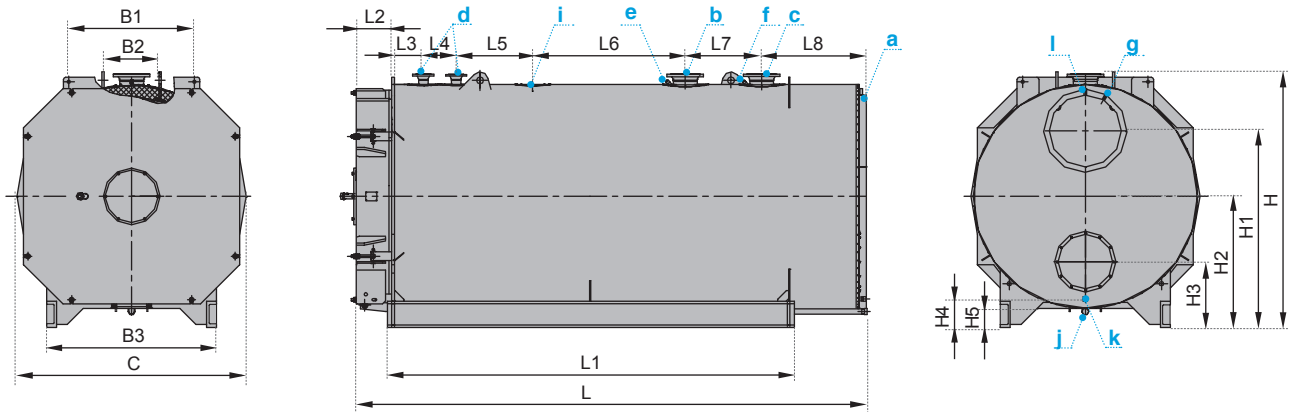

Overall and connecting dimensions

Rated heat output, kW		1,000	2,000	2,500	3,000	3,500	4,200	5,400	6,500	8,000	10,000	12,000	15,000
Flue gas outlet, DN	a	300	500	500	500	500	650	650	800	800	900	1,000	1,000
Water inlet, DN	b	125	150	150	200	200	200	250	250	300	300	350	400
Water outlet, DN	c	125	150	150	200	200	200	250	250	300	300	350	400
Safety valve, DN	d	50	65	65	65	65	80	80	100	100	125	125	125
Temperature sensor (inlet)	e	G 1/2-B											
Temperature sensor (outlet)	f	G 1/2-B											
Flue gas temperature sensor	g	G 1/2-B											
Inspection hole, mm	i	252x190											
Boiler water drainage, mm	j	40						50					
Condensate removal	k	G 1-B											
Draft and heat gauge	l	G 1/2-B											
Length, mm	L	2,747	3,323	3,573	4,064	4,370	4,819	4,991	5,352	5,648	6,289	6,805	7,401
Width, mm	B	1,540	1,740	1,740	1,944	1,940	2,100	2,200	2,360	2,500	2,680	2,860	3,060
Height, mm	H	1,768	2,043	2,043	2,228	2,228	2,430	2,420	2,574	2,710	2,862	3,074	3,276
Length of supporting frame, mm	L1	2,240	2,460	2,710	3,120	3,520	3,687	3,869	4,200	4,500	5,135	5,470	6,135
Cover width, mm	L2	225	275	275	325	325	325	323	327	325	327	329	329
Distance, mm	L3	333	133	133	133	128	276	276	448	608	481	414	574
Distance, mm	L4	300	250	250	300	300	300	300	470	500	500	500	600
Distance, mm	L5	300	400	400	400	400	700	700	470	490	500	440	850
Distance, mm	L6	430	900	1,150	1,250	1,650	1,400	1,400	1,500	1,500	1,850	2,000	1,700
Distance, mm	L7	400	550	550	600	600	700	800	900	1,000	1,400	1,600	2,000
Distance, mm	L8	745	803	803	952	955	1,010	1,178	1,134	1,213	1,217	1,506	1,332
Distance, mm	B1	-	1,150	1,150	1,150	1,150	1,150	1,150	1,150	1,150	1,150	1,150	1,150
Distance, mm	B2	490	500	500	500	500	500	670	738	960	660	762	760
Width of supporting frame, mm	B3	910	1,152	1,152	1,152	1,152	1,528	1,540	1,580	1,800	1,800	1,820	1,940
Distance, mm	H1	1,360	1,555	1,555	1,760	1,760	1,857	1,888	1,970	2,070	2,130	2,364	2,514
Distance, mm	H2	910	1,085	1,085	1,170	1,170	1,257	1,238	1,314	1,370	1,450	1,564	1,664
Distance, mm	H3	560	610	610	620	620	657	638	614	620	700	614	614
Distance, mm	H4	239	315	315	301	301	323	245	237	213	290	227	230
Distance, mm	H5	107	181	181	166	166	163	109	120	92	91	105	105

Note. The boilers with heat output of 1,000 kW and 1,500 kW have no slinging holes (distance B1). Dimensions L3–L6 in accordance with the diagram on page 36.

Dimensions of boiler TT100-01 firebox

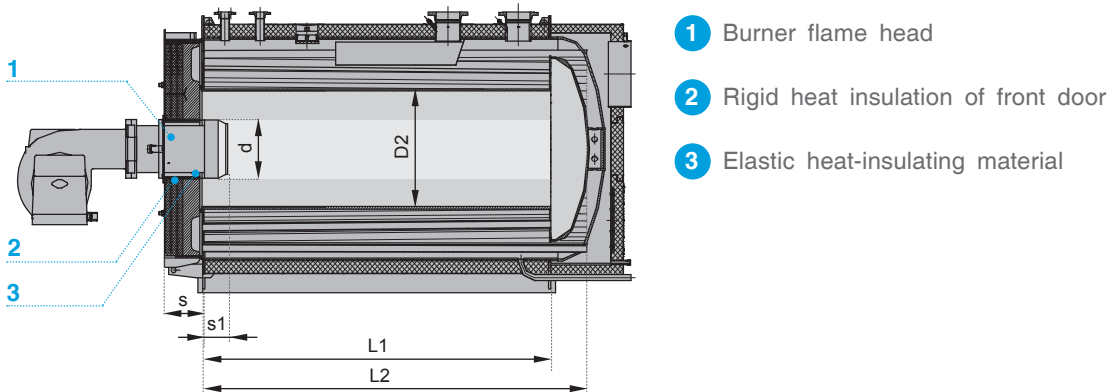

Burner installation

Boiler size	1,000	2,000	2,500	3,000	3,500	4,200	5,400	6,500	8,000	10,000	12,000	15,000
Diameter of installation hole, d, mm	310	380	380	450	450	480	450	500	590	590	730	730
Thickness of cover, taking into account the adapter plate, s, mm	247	297	297	347	347	347	345	349	347	349	347	347
Installation size of burner, s1, mm	20–60											
Firebox diameter, D2, mm	600	780	780	900	900	1,000	1,100	1,180	1,280	1,380	1,500	1,600
Flue tube length, L1, mm	1,905	2,355	2,605	2,905	3,305	3,650	3,805	4,105	4,470	5,105	5,405	6,105
Firebox length, L2, mm	2,139	2,628	2,878	3,223	3,623	3,975	4,156	4,503	4,888	5,538	5,891	6,614

Selection and installation of the burner

The aerodynamic characteristics of the burners and their placement shall ensure that the flame fills the firebox uniformly without affecting the firebox material and prevent any areas becoming stagnant or poorly ventilated within the firebox volume.

Burners to be used with ENTROPIE boilers TT100-01 shall have a forced air supply with a regulated air excess factor. Starting up burners, combustion chamber blowing, operation, and shutdown should be performed automatically.

ENTROPIE boilers TT100-01 are operated with excess pressure in the firebox. In selecting burners, it is necessary to take into account the following factors:

- length and diameter of the firebox,
- aerodynamic drag of the boiler.

Hot water ENTROPIE boilers TT100-01 can be operated with rotary fan combined burners designed for combustion of gas and liquid fuel. The burner model shall pass industrial tests and meet the requirements of DIN EN 267, 676. To order a hot water ENTROPIE boiler TT100-01 complete with burner, it is necessary to indicate the gas pressure in case of using gas as the main or reserve fuel.

When ordering a burner, check that its connecting dimensions and flame head dimensions comply with the technical requirements for the boiler and this technical data sheet. An additional extension and/or intermediate flange shall be ordered when the burner is fitted with a long flame head. Manufacture of a special door for installation of a burner with individual characteristics is possible.

The burner gas line shall contain a compensator. It will relieve mechanical loads on the gas pipeline during boiler maintenance and operation.

The burner flame head is equipped according to the manufacturer's requirements. The burner flame head shall be inserted in the firebox, taking into account the dimensions s1.

The space between the burner flame head and rigid heat insulation of the boiler front door should be sealed with an elastic heat-insulating material attached to the boiler (this should be installed around the perimeter of the burner hole on the front door).

Quality of boiler water

Operating the boiler without water treatment is prohibited. Special attention should be paid to the quality of the boiler water, which in most cases is the main factor affecting the service life of the boiler and the boiler unit as a whole. The water regime shall ensure that the boiler operates without its parts being damaged by lime-scale or sludge deposits, or as a result of metal corrosion, mostly caused by deviating from the standard quality indicators given in the table to the right.

The water composition at the boiler inlet shall comply with the specified indicator values.

The water treatment log-book shall always be available in the boiler room, in which information on

Description of indicator	Value
Transparency of water by font (using the Snellen method), cm, min	30
Carbonate hardness, mkg-equiv./kg, max	700
Content of dissolved oxygen, µg/kg, max	50
Content of iron compounds (in terms of Fe), µg/kg, max	500
pH value at 25 °C	7–11
Free carbonic acid, mg/kg	None
Content of oil products, mg/kg, max	1

the water-chemical conditions of the boiler should be recorded.

Boiler configuration

Several options of boiler delivery sets are available depending on the equipment: full delivery set, partial delivery set, or delivery without parts.

The full delivery set includes a boiler with burner equipment, set of parts and components installed according to the information specified in the questionnaire.





Due to factory installation, the optimal and reliable operation of all boiler units is guaranteed.

Elastic material is supplied as part of the boiler delivery set for sealing the annular gap between the burner flame head and rigid thermal insulation of the front door.

On request the boiler can be supplied with the partial delivery set equipment (boiler fitted with a burner and relief valves) or without parts. In the latter case, the customer will independently equip the boiler with burners, safety devices, and automatic controls.

Boiler accessories

On additional request the manufacturer can deliver the following accessories for boilers:

	Plate for burner
	Flange for burner
	Collecting channel of the safety group for connecting sensors and monitoring devices
	Pressure limiters for minimum and maximum pressure
	Safety valves
	Temperature sensors
	Three-way valve
	Boil-off protection sensor
Other accessories for boiler installation and maintenance	

Boiler placement

The distance from the boiler front to the wall of the boiler room shall leave enough space for boiler maintenance and repair, and no less than 3 m. During operation, for boilers running on gaseous or liquid fuel, the distance from the protruding parts of the burner devices to the boiler room wall shall be at least 1 m. The width of passageways between the boiler and the boiler room wall shall be at least 1 m.

In case the boiler is installed near walls or columns, the insulation of the boilers shall not be in close contact with the boiler room wall if there is no

passageway, and there shall be a minimum distance of 70 mm between them.

The width of the passageway between the boiler and the rear wall of the boiler room shall be wide enough for carrying out maintenance, repair, and installation of the connecting element of flue tube. In this case, the width of the passageway shall be at least 1 m.

Deviations from the recommended distances are allowed but only within the distances specified in the local regulatory documents.

Transportation

Subject to the approval of the customer and relevant authorities, the boiler can be transported by any mode of transport.

During boiler transportation, the open flange and fitting connections, cable insertions shall be plugged, all temporary openings shall be closed.

During transportation and storage it is necessary to take precautions in order to protect the boiler against mechanical damages.

Special slinging devices, namely, eye bolts, are provided for the process of loading, unloading, and placing the boiler (units, boiler elements) in its permanent location. Boiler slinging with the use

of other elements is not allowed. Operation of hoisting devices shall prevent any sliding (dragging) of any part, unit and vehicles along the surfaces of storage areas.

Slinging and lifting from other parts of the boiler is not allowed!

The boiler shall be loaded on a vehicle using cranes with the corresponding lifting capacity, equipped with beams and lifting devices.

The boiler shall be secured to vehicles in accordance with the corresponding specifications for cargo handling and securing for each mode of transport.

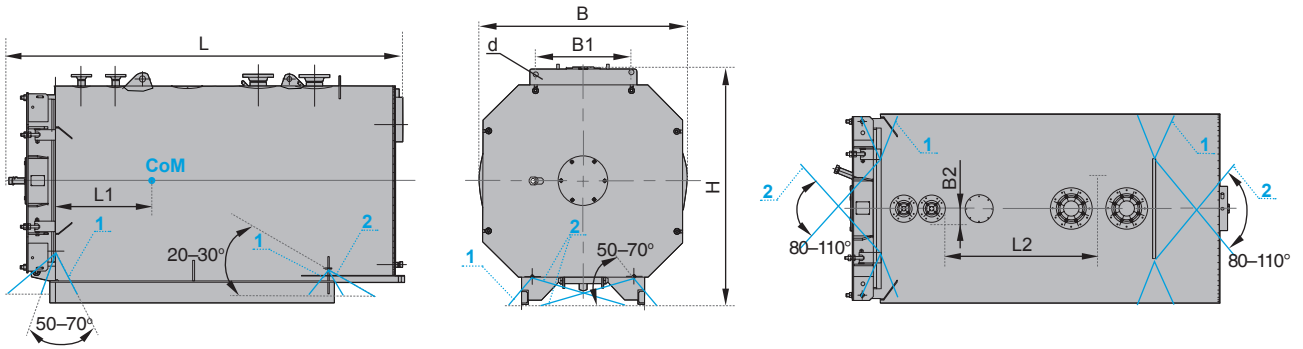

Boiler transportation diagram

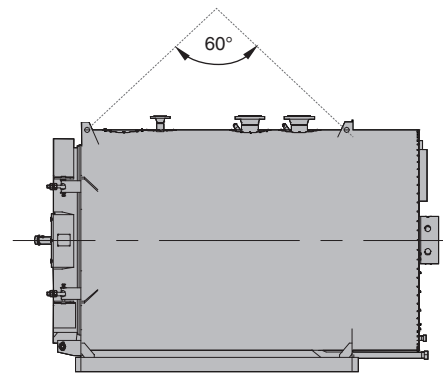

Diagram for boiler slinging

- – Center of mass
- – Means of fastening
- 1 – Tilt protection
- 2 – Diagonal fastening

Description	Numerical value												
	1,000	2,000	2,500	3,000	3,500	4,200	5,400	6,500	8,000	10,000	12,000	15,000	
Rated heat output, kW	1,000	2,000	2,500	3,000	3,500	4,200	5,400	6,500	8,000	10,000	12,000	15,000	
Length, L, mm	2,868	3,443	3,693	4,184	4,485	4,944	5,146	5,503	5,790	6,440	6,962	7,550	
Width, B, mm	1,540	1,740	1,740	1,944	1,940	2,100	2,200	2,360	2,500	2,680	2,860	3,060	
Height, H, mm	1,768	2,043	2,043	2,228	2,228	2,430	2,420	2,574	2,710	2,862	3,074	3,276	
Distance, B1, mm	-	1,150	1,150	1,150	1,150	1,150	1,150	1,150	1,150	1,150	1,150	1,150	
Distance, B2, mm	245	250	250	250	250	250	335	369	480	330	381	380	
Diameter of transportation hole, d, mm	-	28	28	28	28	28	28	28	28	28	28	28	
Center of mass, L1, mm	1,011	1,226	1,364	1,506	1,706	18,72	2,023	2,137	2,266	2,674	2,833	3,191	
Distance, L2, mm	1,100	1,530	1,780	1,525	2,370	2,300	2,300	2,645	3,400	3,325	3,955	4,355	
Weight, m, kg	3,013	4,912	5,361	7,374	8,028	10,175	11,595	14,329	17,486	20,442	24,648	30,432	

